

# SO-15T

Radio Frequency  
Conveyorised Dryer



## Monga Strayfield

Pvt. Ltd.

*THE COST EFFECTIVE SMALL TEXTILE DRYER*



The unique SO-15T Radio Frequency textile dryer from Monga Strayfield

The SO-15T equipment offers a cost effective method of drying smaller textile batches. Designed to process all types of textile materials like fiber, hanks, muffs, tops, and yarn packages wound on S.S. Dye springs, cones & cheese.

The SO-15T features benefits of flexibility, precision and efficiency at low rates of electricity consumption similar to higher capacity dryers.

SO - 15T Performance Specifications		
PRODUCT	MOISTURE	PROD./HOUR
Polyester	14% - 2%	150 kgs
Acrylic	15% - 2%	138 kgs
Polyamide	18% - 3%	120 kgs
Wool / Acrylic	33% - 11%	82 kgs
Wool	42% - 17%	72 kgs
Poly / Cotton	30% - 5%	72 kgs
Cotton	52% - 8%	41 kgs
Viscose	80% - 11%	26 kgs
Ramie Cotton	29% - 12%	106 kgs
Angora	45% - 14%	58 kgs
Acrylic / Cotton	35% - 3%	56 kgs
Silk	55% - 8%	38 kgs
Rayon	75% - 11%	28 kgs

SO - 15T Technical Specifications	
R F Power	15 kW
Frequency	27.12 MHz
Conversion Efficiency	70% - 75%
Unit Cooling	Forced Air Cooled
Electrical Supply	410V 3ph 50Hz 0.9 Cosø
Electrical Power	26 kW Max
Modular Conveyor	800 mm wide

Features
<b>IMPROVED PRODUCT QUALITY</b>
No dye migration
No pigment contamination
Uniform drying
Automati cmoistur econtrol
<b>ENERGY SAVINGS</b>
No warm-up time
No radiated heat loss
Lowe renerg ycost s /kg.product
<b>ECO FRIENDLY</b>
No effluents and flues
No radiate dheat
Cleane rworkin genvironmen t
No steam required
<b>ECONOMIC FEASIBILITY</b>
Rapi dpa yback
Optima lenerg yutilization
Consisten tproduc tquality
Synchronizatio nwith hassociate din-lin eprocesses
<b>AFTER SALES SUPPORT</b>
Spare sa tshorte rdeliver yperiods
Importe dspare savailable l ocall
Professiona l,sta fftraine db yStrayfiel dLtd .,UK

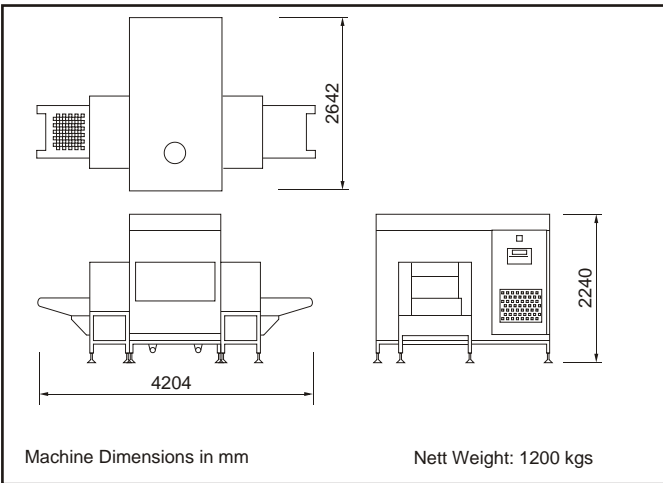

Note : Specifications / illustrations given herein are tentative.

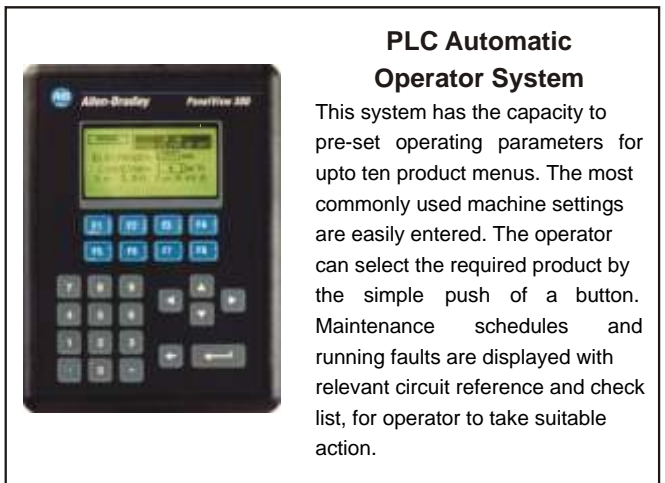

# Monga Strayfield Pvt. Ltd.

Registered Office :  
 5, Arun Bazar, S. V. Road,  
 Malad (W), Mumbai - 400 064.  
 Tel.: +91(0) 22 - 2882 1334, 2882 1662  
 Fax : +91(0) 22 - 2889 5654  
 E-mail : note@vsnl.com

Works :  
 483/1/B, Medankarwadi, Chakan,  
 Tal : Khed, Dist : Pune-410 501  
 Tel.: +91-(0) 2135 - 253177/78  
 Fax : +91-(0) 2135 - 254599  
 Website : www.mongagroup.com

Sole Selling Agents:  
 **STAFI INTERNATIONAL**

101, Vardhaman Indl. Complex, Old Agra Road,  
 Thane - 400 601. Tel.: 00-91-22-2540 7918 / 2543 7401  
 Fax: 00-91-22-2541 4299 E-mail:stafi@vsnl.com  
 Website : www.stafiinternational.com