



The PS-20T Batch Dryer equipment offers a cost effective method of drying textile batches optimally. Designed to process all types of textile materials like fibre, hanks, muffs, tops, and yarn packages wound on S.S. dye springs, cones & cheese. The PS-20T features benefits of flexibility, precision and efficiency at optimum electricity consumption. Monitored and controlled by a P.L.C. for high quality finished product.

PS-20T  
Radio Frequency



BATCH DRYER



BATCH DRYER



BATCH DRYER



# The PS-20T Radio Frequency BATCH DRYER

## The PS-20T Performance Specifications (Dye Spring Wound Cheese Packages)

PRODUCT	MOISTURE	PROD./HOUR
Polyester	14%- 2%	200 kgs
Acrylic	15%- 2%	185 kgs
Polyamide	18%- 3%	160 kgs
Wool / Acrylic	33% - 11%	109 kgs
Wool	42% - 17%	96 kgs
Poly / Cotton	30% - 5%	96 kgs
Cotton	52% - 8%	55 kgs
Viscose	80% -11%	35 kgs
Ramie Cotton	29% - 12%	141 kgs
Angora	45% - 14%	77 kgs
Acrylic / Cotton	35% - 3%	75 kgs
Silk	55% - 8%	51 kgs

## The PS-20T Technical Specifications

R F Power	20 kW
Frequency	27.12 MHz
Conversion Efficiency	0% - 75%
Unit Cooling	Air Cooled
Electrical Supply	410V 3ph 50Hz 0.9 Cos Ø
Electric Power	36 kW Max

## Features

IMPROVED PRODUCT QUALITY
No dye migration
No pigment contamination
Uniform drying
Automatic moisture control
ENERGY SAVING
No warm-up time
No radiated heat loss
Lower energy cost/kg. product
ECO FRIENDLY
No effluents and flues
No radiated heat
No steam required
ECONOMIC FEASIBILITY
Consistent product quality
Synchronisation with associated in-line processes
AFTER SALES SUPPORT
Spares at shorter delivery periods
Imported spares available locally
Professional staff, trained by Strayfield Ltd.,UK

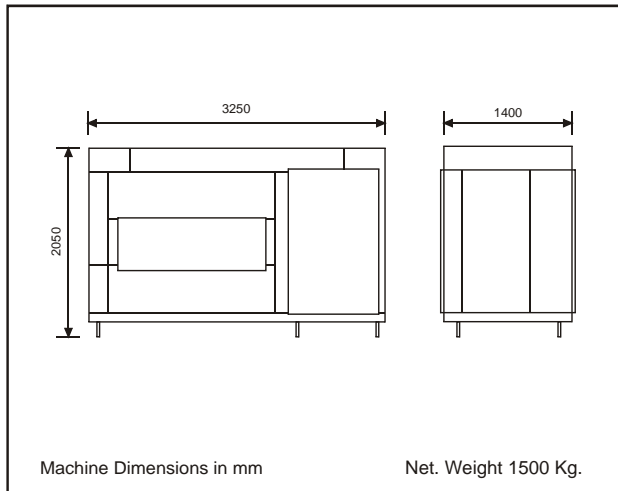

Note : Specifications / illustrations given herein are tentative.

## PLC Automatic Operator System



This system has the capacity to pre-set operating parameters for upto ten product menus. The most commonly used machine settings are easily entered. The operator can select the required product by the simple push of a button. Maintenance schedules and running faults are displayed with relevant circuit reference and check list, for operator to take suitable action.

 **Monga Strayfield**  
Pvt. Ltd.

Registered Office :  
5, Arun Bazar, S. V. Road,  
Malad (W), Mumbai - 400 064.  
Tel.: +91(0) 22 - 2882 1334, 2882 1662  
Fax : +91(0) 22 - 2889 5654  
E-mail : note@vsnl.com

Works :  
483/1/B, Medankarwadi, Chakan,  
Tal : Khed, Dist : Pune-410 501  
Tel.: +91-(0) 2135 - 253 177/78  
Fax : +91-(0) 2135 - 254 599  
Website : www.mongagroup.com

Sole Selling Agents:

 **STAFI INTERNATIONAL**

101, Vardhaman Indl. Complex, Old Agra Road,  
Thane - 400 601. Tel.: 00-91-22-2540 7918 / 2543 7401  
Fax: 00-91-22-2541 4299 E-mail:stafi@vsnl.com  
Website : www.stafiinternational.com