

PS-12T Radio Frequency

 **Monga Strayfield**
Pvt. Ltd.

BATCH DRYER
BATCH DRYER
BATCH DRYER
BATCH DRYER



The PS-12T Batch Dryer equipment offers a cost effective method of drying smaller textile batches.

Designed to process all types of textile materials like fibre, hanks, muffs, tops, and yarn packages wound on S.S. dye springs, cones & cheese. The PS-12T features benefits of flexibility, precision and efficiency at low rates of electricity consumption similar to higher capacity conveyerised dryers.

Monitored and controlled by a P.L.C. for high quality finished product at optimum production rates.

The PS-12T Performance Specifications

PRODUCT	MOISTURE	PROD./HOURLY
Polyester	14%- 2%	120 kgs
Acrylic	15%- 2%	111 kgs
Polyamide	18%- 3%	96 kgs
Wool / Acrylic	33% - 11%	65 kgs
Wool	42% - 17%	58 kgs
Poly / Cotton	30% - 5%	58 kgs
Cotton	52% - 8%	33 kgs
Viscose	80% -11%	21 kgs
Ramie Cotton	29% - 12%	85 kgs
Angora	45% - 14%	46 kgs
Acrylic / Cotton	35% - 3%	45 kgs
Silk	55% - 8%	31 kgs
Rayon	75% - 11%	23 kgs

The PS-12T Technical Specifications

R F Power	12 kW
Frequency	27.12 MHz
Conversion Efficiency	70% - 75%
Unit Cooling	Forced Air Cooled
Electrical Supply	410V 3ph 50Hz 0.9 Cosø
Electrical Power	24 kW Max

Features

IMPROVED PRODUCT QUALITY

No dye migration

No pigment contamination

Uniform drying, consistent product quality

Automatic moisture control

ENERGY SAVINGS

No warm-up time

No radiated heat loss

Lower energy cost / kg. product

ECO FRIENDLY

No effluents and flues

Cleaner working environment

No steam required

ECONOMIC FEASIBILITY

Rapid pay back

Synchronisation with associated in-line processes

AFTER SALES SUPPORT

Spares at shorter delivery periods

Imported spares available locally

Professional, staff trained by Strayfield Ltd.,UK

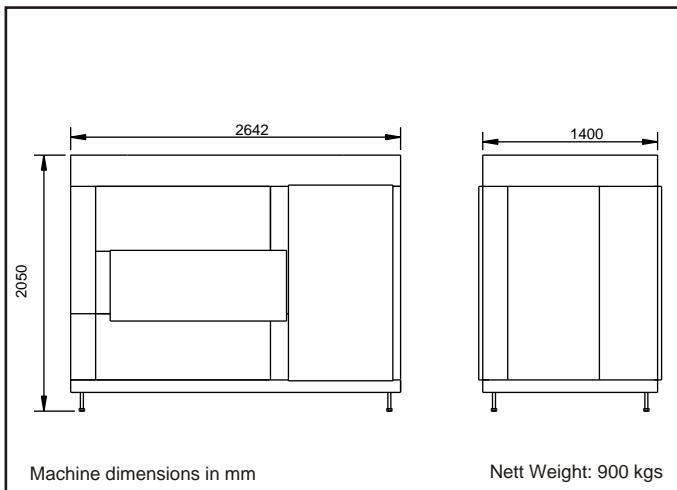

Note : Specification / illustrations given herein are tentative.

 **Monga Strayfield**
Pvt. Ltd.

Registered Office :
5, Arun Bazar, S. V. Road,
Malad (W), Mumbai - 400 064.
Tel.: +91(0) 22 - 2882 1334, 2882 1662
Fax : +91(0) 22 - 2889 5654
E-mail : note@vsnl.com

Works :
483/1/B, Medankarwadi, Chakan,
Tal : Khed, Dist : Pune-410 501
Tel.: +91-(0) 2135 - 253177/78
Fax : +91-(0) 2135 - 254599
Website : www.mongagroup.com

PLC Automatic Operator System



This system has the capacity to pre-set operating parameters for upto ten product menus. The most commonly used machine settings are easily entered. The operator can select the required product by the simple push of a button. Maintenance schedules and running faults are displayed with relevant circuit reference and check list, for operator to take suitable action.

Sole Selling Agents:

 **STAFI INTERNATIONAL**

101, Vardhaman Indl. Complex, Old Agra Road,
Thane - 400 601. Tel.: 00-91-22-2540 7918 / 2543 7401
Fax: 00-91-22-2541 4299 E-mail:stafi@vsnl.com
Website : www. stafiinternational.com