

Radio Frequency Dryer Lab Model

Suited for a wide range
of textile products like
Hanks, Muffs, Cones,
Tops, Fibres & Cheeses

Ideal for Test Batches
and Sampling Runs



 **Monga Strayfield**
A Joint Venture of
STRAYFIELD LIMITED, UK & MONGA ELECTRONICS PVT. LTD. **Pvt. Ltd.**

Laboratory Dryer Performance Specifications

PRODUCT	MOISTURE	1 kw	2 kw	3 kw	6 kw
Polyester	14% - 2%	10.0	20.0	30.0	60.0
Acrylic	15% - 2%	9.2	18.5	27.7	55.4
Polyamide	18% - 3%	8.0	16.0	24.0	48.0
Wool/Acrylic	33% - 11%	5.5	10.9	16.4	32.7
Wool	42% - 17%	4.8	9.6	14.4	28.8
Poly / Cotton	30% - 5%	4.8	9.6	14.4	28.8
Cotton	52% - 8%	2.7	5.5	8.2	16.4
Viscose	80% - 11%	1.7	3.5	5.2	10.4
Ramie Cotton	29% - 12%	7.1	14.1	21.2	42.4
Angora	45% - 14%	4.0	8.0	12.0	23.0
Acrylic/Cotton	35% - 3%	3.8	7.5	11.3	22.5
Silk	55% - 8%	2.6	5.1	7.7	15.3
Rayon	75% - 11%	1.9	3.8	5.6	11.3

Technical Specifications

R F Power kW	1 - 2 - 3 - 6
Frequency	27.12 MHz
Moisture Evaporation	1.2 / 2.4 / 3.6 / 7.2 / kgs/Hr
Conversion Efficiency	70% - 75%
Unit Cooling	Forced Air Cooled
Electrical Supply	410V 3ph 50Hz 0.9 Cos ϕ 2, 3 & 6kW Models 230V 1ph 50Hz 0.9 Cos ϕ 1kW Model
Electric Power	2.5, 4.3, 5.8, 11.5 Max (1,2,3,6 kW models)

Features

ECO FRIENDLY

- No effluents and flues
- No radiated heat
- No steam required
- Uniform dryness profile adds value to final product
- Reduces loss of flavours & food values
- Improve production speed

AFTER SALES SUPPORT

- Spares at shorter delivery periods
- Imported spares available locally
- Professional staff, trained by Strayfield Ltd.,UK

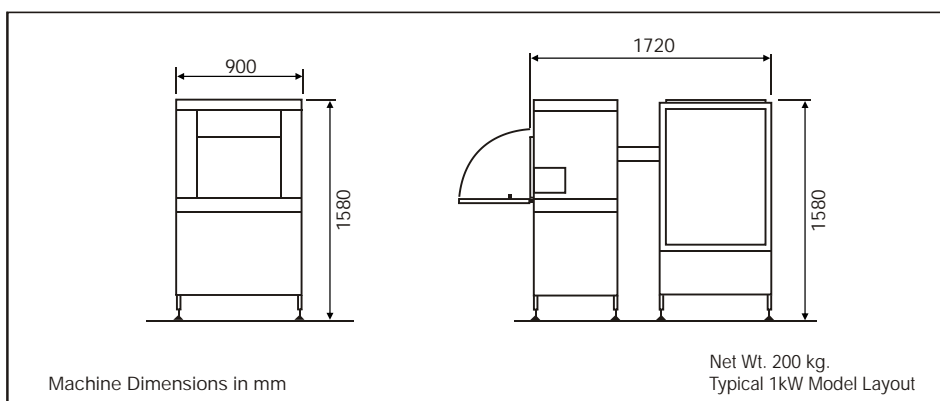

Note : Specifications / illustrations given herein are tentative.

 **Monga Strayfield**

A Joint Venture of
STRAYFIELD LIMITED, UK & MONGA ELECTRONICS PVT. LTD. **Pvt. Ltd.**

Registered Office :
5, Arun Bazar, S. V. Road,
Malad (W), Mumbai - 400 064.
Tel.: +91(0) 22 - 2882 1334, 2882 1662
Fax : +91(0) 22 - 2889 5654
E-mail : note@vsnl.com

Works :
483/1/B, Medankarwadi, Chakan,
Tal : Khed, Dist : Pune-410 501
Tel.: +91-(0) 2135 - 253 177/78
Fax : +91-(0) 2135 - 254 599
Website : www.mongagroup.com

Sole Selling Agents:

 **STAFI INTERNATIONAL**

101, Vardhaman Indl. Complex, Old Agra Road,
Thane - 400 601. Tel.: 00-91-22-2540 7918 / 2543 7401
Fax: 00-91-22-2541 4299 E-mail:stafi@vsnl.com
Website : www.stafiinternational.com